

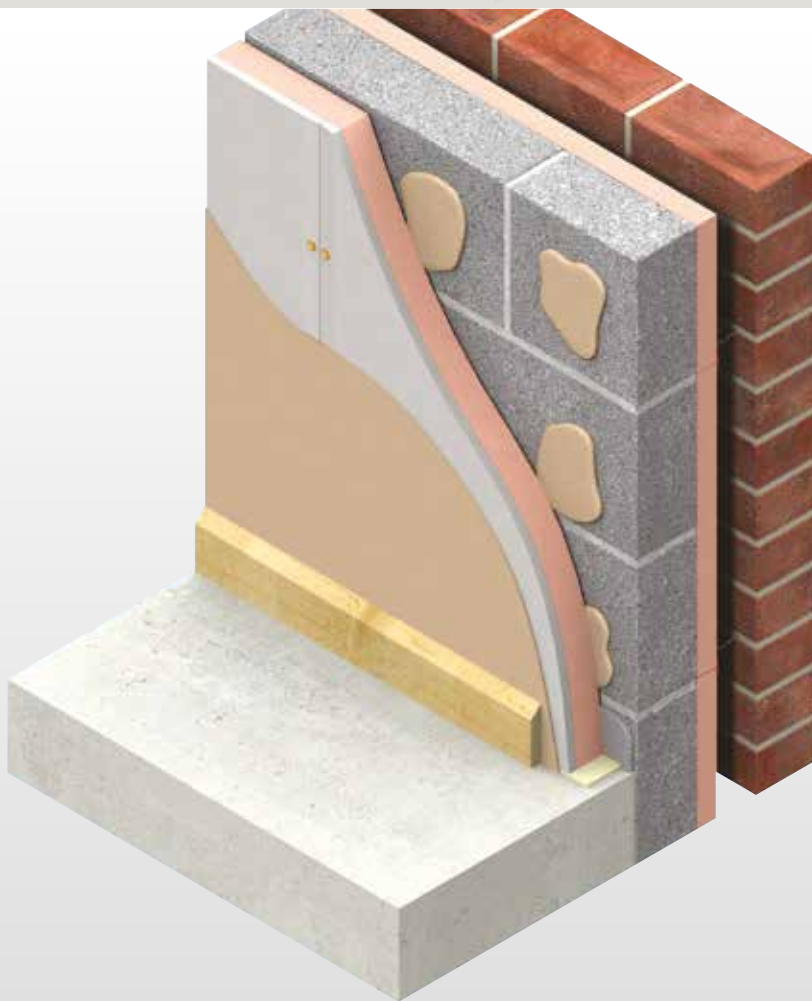

Kooltherm® K17 Insulated Plasterboard

INSULATED PLASTERBOARD FOR PLASTER DAB / ADHESIVE BONDED DRY-LINING



- Premium performance rigid thermoset insulation – thermal conductivities as low as 0.020 W/m·K
- Class 0 fire rating
- Insulation, dry-lining and vapour control in one board
- Allows quick response heating
- Unaffected by air infiltration
- Resistant to the passage of water vapour
- Easy to handle and install
- Ideal for new build and refurbishment
- Non-deleterious material
- Manufactured with a blowing agent that has zero ODP and low GWP

Fibre-free
Core

Kingspan®

*Low Energy –
Low Carbon Buildings*

Typical Constructions and U-values

Assumptions

The U-values in the tables that follow have been calculated, under a management system certified to the BBA Scheme for Assessing the Competency of Persons to Undertake U-value and Condensation Risk Calculations, using the method detailed in BS EN ISO 6946: 2017 / I.S. EN ISO 6946: 2007 (Building components and building elements. Thermal resistance and thermal transmittance. Calculation methods), and using the conventions set out in BR 443 (Conventions for U-value calculations). They are valid for the constructions shown in the details immediately above each table.

These examples are based on the use of 3 mm skim coated **Kingspan Kooltherm® K17 Insulated Plasterboard** dot and dab bonded to the construction described.

NB When calculating U-values to BS EN ISO 6946: 2017 / I.S. EN ISO 6946: 2007, the type of mechanical fixing used may change the thickness of insulation required. These calculations assume dot and dab bonded insulated plasterboard and the use of two nailable plugs per board. Calculations assume the effect of nailable plugs on the U-value to be insignificant and therefore no correction factor for mechanical fixings has been taken.

NB For the purposes of these calculations the standard of workmanship has been assumed good, and therefore the correction factor for air gaps has been ignored.

NB The figures quoted are for guidance only. A detailed U-value calculation and a condensation risk analysis should be completed for each project.

NB If your construction is different from those specified, and / or to gain a comprehensive U-value calculation along with a condensation risk analysis of your project, please consult the Kingspan Insulation Technical Service Department for assistance (see rear cover).



Masonry Cavity Walls

**102.5 mm Brick Outer Leaf / Cavity /
102.5 mm Brick Inner Leaf**

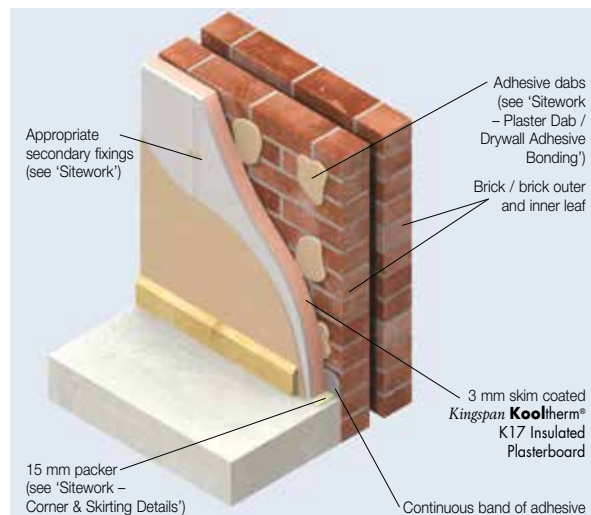

Figure 1

U-values for Various Product Thicknesses of **Kingspan Kooltherm® K17 Insulated Plasterboard**

Product Thickness* (mm)	U-values (W/m ² ·K)
57.5	X
62.5	0.30
72.5	0.26
82.5	0.23
87.5	0.22
92.5	0.21

* Product thickness = insulant thickness + 12.5 mm plasterboard.

NB Refer to local distributor or Kingspan Insulation price list for current stock and non-stock sizes.

U-value Table Key

Where an **X** is shown, the U-value is higher than the worst of the maximum new build area weighted average U-values allowed by the:

- 2013 editions of Approved Documents L to the Building Regulations for England;
- 2014 editions of Approved Documents L to the Building Regulations for Wales;
- 2015 editions of Technical Handbooks Section 6 to the Building Standards for Scotland;
- 2012 editions of Technical Booklets F1 & F2 to the Building Regulations for Northern Ireland; and
- 2011 edition of Technical Guidance Document L (Dwellings) and 2008 edition of Technical Guidance Document L (Buildings other than Dwellings) to the Building Regulations for the Republic of Ireland.

10 mm Polymer Rendered 100 mm Block Outer Leaf / Cavity / 100 mm Block Inner Leaf

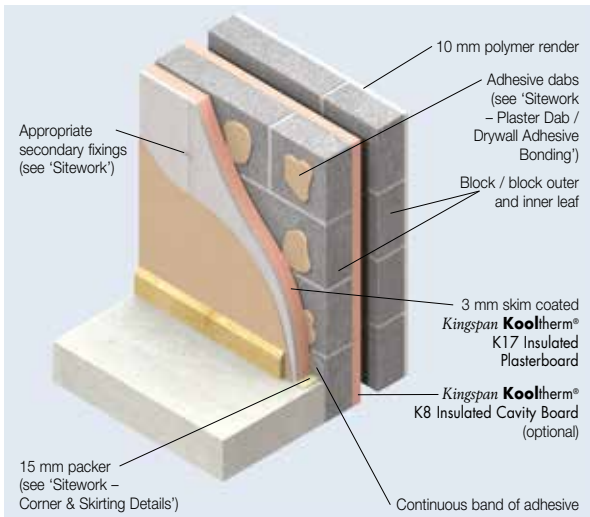

Figure 2

102.5 mm Brick Outer Leaf / Cavity / 100 mm Block Inner Leaf

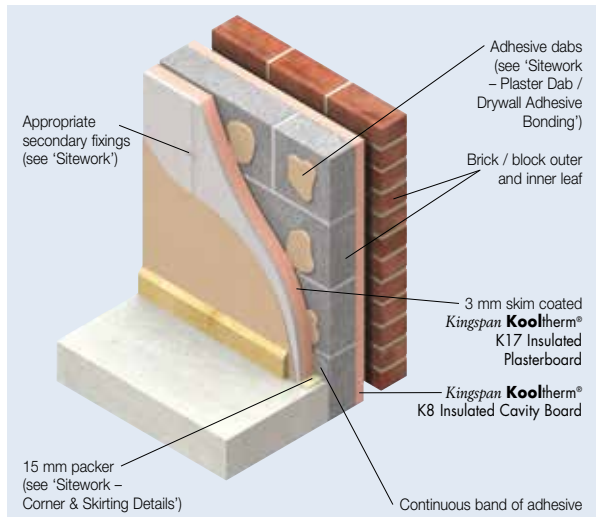

Figure 3

U-values (W/m²·K) for Various Product Thicknesses of Kingspan Kooltherm® K17 Insulated Plasterboard and Thicknesses of Kingspan Kooltherm® K8 Cavity Board

Kooltherm® K17 Product Thickness* (mm)	Inner & Outer Leaf Blockwork Density and λ-value (W/m·K)	
	Dense (1.13)	Medium (0.51)
Clear Cavity		
47.5	X	X
52.5	X	0.34
57.5	0.33	0.30
62.5	0.30	0.28
72.5	0.26	0.25
82.5	0.23	0.22
87.5	0.22	0.21
92.5	0.21	0.20
100 mm Cavity Partially Filled with 50 mm of Kingspan Kooltherm® K8 Cavity Board†		
32.5	0.21	0.20
37.5	0.20	0.19
42.5	0.19	0.18
52.5	0.18	0.17
62.5	0.16	0.15
100 mm Cavity Partially Filled with 60 mm of Kingspan Kooltherm® K8 Cavity Board†		
32.5	0.19	0.19
37.5	0.18	0.18
42.5	0.17	0.17
52.5	0.16	0.16
62.5	0.15	0.14

* Product thickness = insulant thickness + 12.5 mm plasterboard.

† Please read the section entitled 'Residual Cavity Width' in the literature for Kingspan Kooltherm® K8 Cavity Board for details of cavity width requirements in the UK and Ireland.

NB Refer to local distributor or Kingspan Insulation price list for current stock and non-stock sizes.

U-values (W/m²·K) for Various Product Thicknesses of Kingspan Kooltherm® K17 Insulated Plasterboard and Thicknesses of Kingspan Kooltherm® K8 Cavity Board

Kooltherm® K17 Product Thickness* (mm)	Inner Leaf Blockwork Density and λ-value (W/m·K)				
	Dense (1.13)	Medium (0.51)	Lightweight (0.15)**	Aerated (0.11)**	Thin Joint Aerated (0.11)***
Clear Cavity					
37.5	X	X	X	X	X
42.5	X	X	X	0.35	0.35
47.5	X	X	0.34	0.32	0.32
52.5	X	X	0.32	0.30	0.30
57.5	0.33	0.32	0.29	0.27	0.27
62.5	0.30	0.29	0.27	0.25	0.25
72.5	0.26	0.26	0.23	0.23	0.22
82.5	0.23	0.23	0.21	0.20	0.20
87.5	0.22	0.22	0.20	0.19	0.19
92.5	0.21	0.20	0.19	0.18	0.18
100 mm Cavity Partially Filled with 50 mm of Kingspan Kooltherm® K8 Cavity Board†					
32.5	0.22	0.21	0.20	0.19	0.19
37.5	0.20	0.20	0.18	0.18	0.18
42.5	0.19	0.19	0.18	0.17	0.17
52.5	0.18	0.17	0.16	0.16	0.16
62.5	0.16	0.16	0.15	0.14	0.14
100 mm Cavity Partially Filled with 60 mm of Kingspan Kooltherm® K8 Cavity Board†					
32.5	0.19	0.19	0.18	0.17	0.17
37.5	0.18	0.18	0.17	0.16	0.16
42.5	0.18	0.17	0.16	0.16	0.16
52.5	0.16	0.16	0.15	0.15	0.15
62.5	0.15	0.15	0.14	0.13	0.13

* Product thickness = insulant thickness + 12.5 mm plasterboard.

** A 6.6% thermal bridging factor has been assumed for the effect of mortar joints.

*** A 1.4% thermal bridging factor has been assumed for the effect of mortar joints.

† Please read the section entitled 'Residual Cavity Width' in the literature for Kingspan Kooltherm® K8 Cavity Board for details of cavity width requirements in the UK and Ireland.

NB Refer to local distributor or Kingspan Insulation price list for current stock and non-stock sizes.

Typical Constructions and U-values

Solid Masonry Walls

10 mm Polymer Rendered 215 mm Blockwork

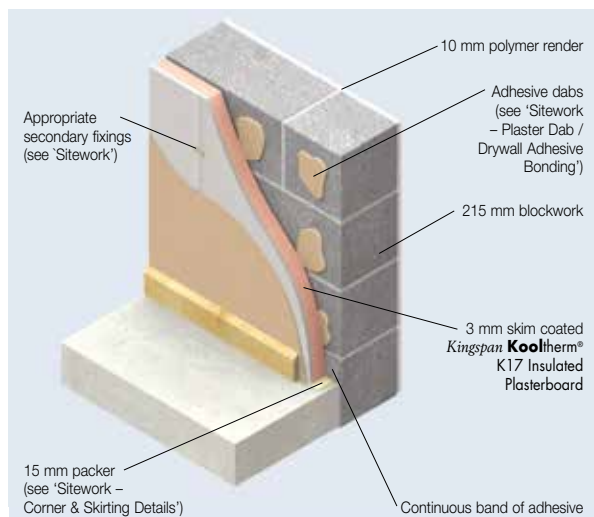

Figure 4

Solid Brickwork with Existing Lining

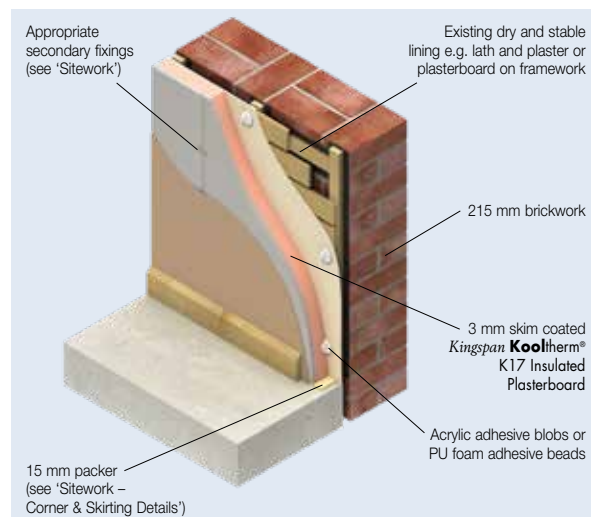

Figure 5

U-values (W/m ² ·K) for Various Product Thicknesses of Kingspan Kooltherm® K17 Insulated Plasterboard					
Product Thickness* (mm)	Blockwork Density and λ-value W/m·K				
	Dense (1.13)	Medium (0.51)	Lightweight (0.15)**	Aerated (0.11)**	Thin Joint Aerated (0.11)***
32.5	X	X	X	0.35	0.34
37.5	X	X	0.35	0.31	0.31
42.5	X	X	0.32	0.29	0.28
52.5	X	X	0.28	0.25	0.25
57.5	0.34	0.32	0.26	0.23	0.23
62.5	0.32	0.30	0.24	0.22	0.22
72.5	0.27	0.26	0.21	0.20	0.20
82.5	0.24	0.23	0.19	0.18	0.18
87.5	0.23	0.22	0.18	0.17	0.17
92.5	0.21	0.21	0.18	0.17	0.16

* Product thickness = insulant thickness + 12.5 mm plasterboard.

** A 6.6% thermal bridging factor has been assumed for the effect of mortar joints.

*** A 1.4% thermal bridging factor has been assumed for the effect of mortar joints.

NB Refer to local distributor or Kingspan Insulation price list for current stock and non-stock sizes.

Kooltherm® K17 Insulated Plasterboard Product Thickness* (mm)	U-values (W/m ² ·K)
52.5	X
57.5	0.33
62.5	0.31
72.5	0.27
82.5	0.24
87.5	0.22
92.5	0.21

* Product thickness = insulant thickness + 12.5 mm plasterboard.

NB Refer to local distributor or Kingspan Insulation price list for current stock and non-stock sizes.

Linear Thermal Bridging at Junctions

Basic Principles

Linear thermal bridging describes the heat loss at junctions between elements, which is additional to the losses occurring through roofs, walls and floors. This heat loss is represented by the junction's psi (Ψ) value. The lower the Ψ -value, the better the performance of a junction detail. The Ψ -values and lengths of linear thermal bridges are accounted for in a new building's energy and carbon dioxide emissions calculations. Existing building junction losses are not typically accounted for in whole building heat loss calculations and only the risk of surface condensation and mould growth are considered.

Heat typically flows through the easiest path, for example in a masonry cavity wall the linear thermal bridge is primarily the inner leaf of masonry and in a timber frame wall the linear thermal bridge is primarily the sole plate and the construction below it. These linear thermal bridges can be reduced by increasing the distance that the heat has to travel.

Whilst there are some 'approved' details available, they are specifically targeted at new build constructions. However, where applicable, they are also considered good practice for refurbishment.

Reducing Linear Thermal Bridging

Detailing at junctions to minimise the effects of thermal bridging and the associated risk of condensation or mould growth is important and there are some simple design considerations that can be adopted when insulating internally to help mitigate the risks and to reduce heat loss.

At a window or door opening, the primary linear thermal bridge is the reveal. This heat loss can be reduced by insulating the reveal. The key factor is the thermal resistance (R-value) of the insulation layer. Reveals should be designed to accommodate 32.5 mm (min.) of **Kingspan Kooltherm® K17 Insulated Plasterboard**.

The application of internal insulation above and below an intermediate floor reduces the overall heat loss, but can increase the losses through the intermediate or separating floor. To reduce these losses, where possible, the edge of the intermediate floor within the floor void should also be insulated.

Where the properties to both sides of a party wall are to be insulated, best practice to minimise heat losses through the junction with external walls would be to return the insulation back along the party wall for at least 400 mm back from the external wall.

NB Where insulating the external walls to only one side of a party wall, and the other property remains uninsulated, it is better not to insulate back along the return, as this can increase the losses to the uninsulated side, increasing the risk of surface condensation and mould growth for the uninsulated property.

For further advice on details to reduce linear thermal bridging please contact the Kingspan Insulation Technical Service Department (see rear cover for details).

Design Considerations

Environmental Impact & Responsible Sourcing

Green Guide Rating

An Ecoprofile, certified by BRE Certification to the 2008 BRE Environmental Profiles Methodology, has been created for the insulation component of **Kingspan Kooltherm® K17 Insulated Plasterboard** produced at Kingspan Insulation's British manufacturing facilities. The BRE has assigned the product a 2008 Green Guide Summary Rating of A+.



Environmental Profiles Scheme
Certificate Number ENP 500

Responsible Sourcing

Kingspan Kooltherm® K17 Insulated Plasterboard produced at Kingspan Insulation's Pembridge manufacturing facility is certified to BES 6001 (Framework Standard for the Responsible Sourcing of Construction Products) 'Excellent'.



Kingspan Kooltherm® K17 Insulated Plasterboard is manufactured under a management system certified to ISO 14001: 2004.

The above information is correct at the time of writing. Please confirm at the point of need by contacting Kingspan Insulation's Technical Service Department (see rear cover), from which a copy of Kingspan Insulation's BES 6001 and ISO 14001 certificates can be obtained.

Sustainability & Responsibility

Kingspan Insulation has a long-term commitment to sustainability and responsibility: as a manufacturer and supplier of insulation products; as an employer; as a substantial landholder; and as a key member of its neighbouring communities.

A report covering the sustainability and responsibility of Kingspan Insulation Ltd's operations at its Pembridge, Herefordshire and Selby, North Yorkshire manufacturing facilities is available at

www.kingspaninsulation.co.uk/sustainabilityandresponsibility.

Specification Clause

Kingspan Kooltherm® K17 Insulated Plasterboard should be described in specifications as:-

The wall dry-lining insulation shall be **Kingspan Kooltherm® K17 Insulated Plasterboard** ___ mm thick: comprising a premium performance rigid thermoset insulation core with 12.5 mm plasterboard bonded to its front surface and a glass tissue based facing on its reverse surface.

Design Considerations

The product shall be manufactured: with a blowing agent that has zero Ozone Depletion Potential (ODP) and low Global Warming Potential (GWP); under a management system certified to ISO 9001: 2008, ISO 14001: 2004, BS / I.S. OHSAS 18001: 2007 and ISO 50001: 2011; by Kingspan Insulation Limited; and installed in accordance with the instructions issued by them.

NBS Specifications

Details also available in NBS Plus.

NBS users should refer to clause(s):

K10 145, K10 155, K10 165,

K10 175, K10 205, K10 415

(Standard and Intermediate)

K10 15, K10 35, K10 41 (Minor Works)



Design Standards

BS 8212: 1995 (Code of practice for dry lining and partitioning using gypsum plasterboard) should be considered.

Limitations

Kingspan Kooltherm[®] K17 Insulated Plasterboard has a gypsum plasterboard face. It should, therefore, not be used to isolate dampness, nor be used in continuously damp or humid conditions.

Fire Stops

Current Building Regulations / Standards should be considered with regard to the requirements for and provision of fire stops.

Water Vapour Control / Condensation

Consideration should be given to the risk of condensation, when designing thermal elements.

When internally lining a construction with insulation, condensation can be controlled by ensuring there is a layer of high vapour resistance on the internal surface of the construction. *Kingspan Kooltherm*[®] K17 Insulated Plasterboard contains an integral vapour control layer and, when installed correctly, with appropriate detailing at joints between sheets, penetrations and wall perimeters, can provide the necessary vapour resistance. If required, the vapour resistance of the wall lining can be increased by the application of two coats of Gyproc Drywall Sealer.

A condensation risk analysis should be carried out following the procedures set out in BS 5250: 2011 + A1: 2016 (Code of practice for the control of condensation in buildings). The Kingspan Insulation Technical Service Department (see rear cover) can provide this service.

Sitework

Preparation

- The existing structure should be surveyed to ensure the construction is capable of supporting the weight of the internal wall system, ancillary items and any post-installation fittings.
- Existing wallpaper, skirting, picture rails, gloss paint and projecting window boards must be removed when using adhesively bonded solutions.
- The wall surface should be clean, stable and free from dust, contamination and loose or friable materials.
- The amount of preparation and removal required will be dependent on the chosen internal wall system.
- Check the structure is dry. Remedial work should be undertaken to remove dampness before installation of the internal wall insulation. Internal wall insulation must not be used to isolate dampness.
- Ensure there are no gaps at the perimeter (including floors, ceilings, internal corners or junctions), or around openings or service penetrations. For optimum airtightness, existing gaps should be sealed using a continuous fillet of drywall adhesive or flexible sealant, before wall lining commences.
- Positions for all new services should be determined. Existing services should be assessed to determine any alterations that may need to be made, for example relocating sockets and switches. Wall mounted fixings, such as electrical sockets, should be fitted to take into account the additional wall lining thickness.
- New wall linings must be designed to accommodate the thickness of the new insulated dry lining solution, particularly at reveals, heads, sills and in relation to ceiling height.

Adhesive Bonding

Gypsum Based Drywall Adhesive Dab Bonding

- This method is suitable for use on brick, block or concrete cavity or rendered solid walls, which are dry, stable and free from moisture penetration.
- This method is not suitable for use directly on non-rendered solid masonry walls where there is a risk of moisture penetration, or on timber or steel frame construction.
- The cavity formed by the dabs can be used to incorporate services less than 25 mm in depth. Alternatively, minimum chasing of the background will be required.
- Minor irregularities of the substrate can be corrected within the dab depth. Typically, gypsum based adhesive should be applied in dabs of 10 – 25 mm thickness, therefore the existing substrate should not exceed a 15 mm tolerance from the high spot of the background to either end of the wall.

- A total distance of 10 mm plus the thickness of the *Kingspan Kooltherm*® K17 Insulated Plasterboard should be allowed for from the wall's high point. A line should then be drawn across the floor. This should be plumbed for alignment before transferring the line to the ceiling and extending the line to the room corners. Guidelines should also be marked out vertically on the walls at 1,200 mm horizontal centres to indicate where the edges of the *Kingspan Kooltherm*® K17 Insulated Plasterboard should finish.
- The drywall adhesive should be appropriate for use on the intended masonry substrate. Advice should be sought from the drywall adhesive manufacturer for its recommended system.
- *Kingspan Kooltherm*® K17 Insulated Plasterboard should be cut approximately 15 mm short of the floor to ceiling height.
- A continuous band of drywall adhesive is applied around the perimeter of each wall and around any openings or services, in order to support the insulation board edges.
- Where and if a cavity barrier is required to close the drylining cavity, this can be achieved by applying a continuous band of gypsum adhesive not less than 25 mm wide of sufficient thickness e.g. 12 mm thick minimum, to give continuous contact when *Kingspan Kooltherm*® K17 Insulated Plasterboard is fixed.
- In accordance with Approved Document B or Section 2 of the Scottish Technical Standards, cavity barriers are only required at 20 metre intervals when the cavity is enclosed by a Class 0 material, such as *Kingspan Kooltherm*® K17 Insulated Plasterboard. Cavity barriers are only required on long runs of linings where undivided cavities extend for 20 metres or more.
- The adhesive adjacent to the board joints should be applied approximately 25 mm in from the edge of the boards to avoid bridging the joint.
- Adhesive dabs are generally applied to the background in three vertical rows, but a minimum of 20% of the insulated plasterboard area should be covered with adhesive. Each drywall adhesive dab should be 50 to 75 mm wide and approximately 250 mm long, positioned vertically at approximately 300 mm centres and horizontally at 600 mm centres.
- Sheets of *Kingspan Kooltherm*® K17 Insulated Plasterboard are then located against the adhesive dabs and tapped back to align with predetermined guidelines on the floor and ceiling. The use of a spirit level is recommended to provide a vertical finish.

- Appropriate secondary fixings i.e. nailable plugs or equivalent, are recommended to back up the drywall adhesive dab bond. These are normally applied at a rate of 2 No. per sheet when conventional finishing is applied (plaster skim or tape, filled and painted), after the gypsum based drywall adhesive dabs have set (see Figure 6). Gypsum based drywall adhesive generally sets within 1.5 to 3 hours, following the manufacturer's guidelines.
- If *Kingspan Kooltherm*® K17 Insulated Plasterboard is to receive ceramic wall tiles, additional time, support and fixings will be required to prevent flexing taking place. Horizontal dabs at 1/3 centres in height are required in addition to the normal amount of drywall adhesive to install the system. The amount of secondary fixings should be increased from two fixings per board to nine fixings per board. Installation of the ceramic wall tiles should not be applied to the face of the *Kingspan Kooltherm*® K17 Insulated Plasterboard until 10 days after completing the drywall adhesive bonded lining.
- It is recommended that the secondary fixings are positioned in the tapered edge of the sheets so that they are covered when the board is finished (e.g. joints taped and 3 mm skim coating).

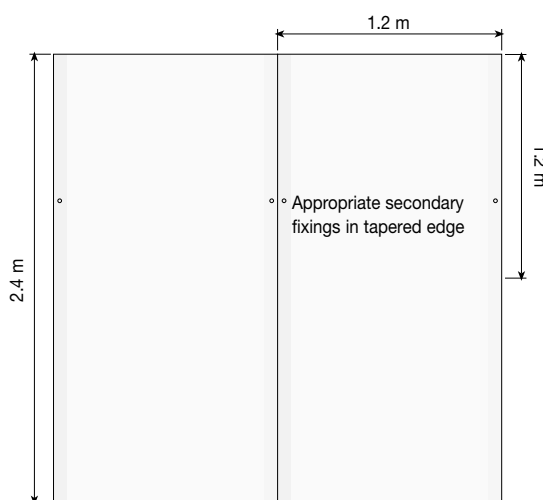

Figure 6 – Appropriate secondary fixing pattern

- Each sheet of insulated plasterboard should be lightly butted.
- The perimeter of the *Kingspan Kooltherm*® K17 Insulated Plasterboard should be sealed. The 15 mm clearance gap at the base of the wall should be sealed with a combination of flexible polyurethane foam and flexible sealant or equivalent.

Sitework

Acrylic Sealant / Low Expansion PU Foam

Adhesive Bonding

- This method is suitable for use on flat brick, block or concrete cavity or rendered solid walls, which are dry, stable and free from moisture penetration.
- This method is also suitable for use on linings such as lath and plaster, plaster or plasterboard, providing the existing structure is dry, stable and free from moisture penetration.
- This method is not suitable for use directly on non-rendered solid masonry walls where there is a risk of moisture penetration.
- In order to provide sufficient space for services, the background will need to be chased out, unless the services exist within the wall or are contained within the lining framework cavity. Existing services should be assessed to determine any alterations that may need to be made, for example relocating sockets and switches.
- The existing substrate should be within a 5 mm tolerance when measured with a 2,000 mm straight edge. A total distance of 2-3 mm plus the thickness of the *Kingspan Kooltherm® K17 Insulated Plasterboard* should be allowed for from the wall's high point. A line should then be drawn across the floor. This should be plumbed for alignment before transferring the line to the ceiling and extending the line to the room corners.
- Guidelines should be marked out on the walls at 1,200 mm horizontal centres to indicate where the edges of *Kingspan Kooltherm® K17 Insulated Plasterboard* should finish.
- *Kingspan Kooltherm® K17 Insulated Plasterboard* should be cut approximately 15 mm short of the floor to ceiling height.
- Acrylic sealant adhesive should be gun-applied to the wall or back of the board in blobs at 300 mm centres, horizontally and vertically.
- PU foam adhesive should be gun-applied to the wall or back of the board in continuous beads 20 – 25 mm wide. A minimum of 3 vertical beads should be applied per board (unless otherwise stated by the PU foam adhesive manufacturer). A continuous bead of PU foam adhesive should also be applied horizontally at the top and the bottom of the board.
- The adhesive adjacent to the board joints should be applied approximately 25 mm in from the edge of the boards to avoid bridging the joint.
- The boards should be lifted tight to the ceiling using a foot-lifter and supported by the packing strips until the adhesive sets. If the wall height exceeds 2,400 mm, start from the bottom of the wall, working upwards, to allow boards to be held on the lower level of the wall and prevent any boards from sliding down.
- The boards should then be tapped back to align with the predetermined guidelines on the floor and ceiling. The use of a spirit level is recommended to provide a vertical plumb finish.
- Sheets of *Kingspan Kooltherm® K17 Insulated Plasterboard* are then located against the adhesive dabs and tapped back to align with predetermined guidelines on the floor and ceiling. The use of a spirit level is recommended to provide a vertical finish.
- Appropriate secondary fixings, i.e. nailable plugs, are recommended to back up the acrylic / low expansion PU foam adhesive bond. These are normally applied at a rate of 2 No. per sheet, when conventional finishing is applied (plaster skim or tape, filled and painted) after the proprietary acrylic or low expansion PU foam adhesive have set (see Figure 6). These types of adhesives set within five minutes to an hour, following the manufacturer's guidelines.
- If *Kingspan Kooltherm® K17 Insulated Plasterboard* is to receive ceramic wall tiles, additional fixings will be required when using these types of adhesives. Increase the amount of secondary fixings from two fixings per board to nine fixings per board.
- It is recommended that secondary fixings are positioned in the tapered edge of the sheets so that they are covered when the board is finished (e.g. joints taped and 3 mm skim coating).
- Each sheet of insulated plasterboard should be lightly butted.
- The perimeter of the *Kingspan Kooltherm® K17 Insulated Plasterboard* should be sealed. The 15 mm clearance gap at the base of the wall should be sealed with a combination of flexible polyurethane foam and flexible sealant or equivalent.

To Timber Joists or Rafters

- Sheets of **Kingspan Kooltherm® K17 Insulated Plasterboard** may be used to line ceilings (see Figure 7).

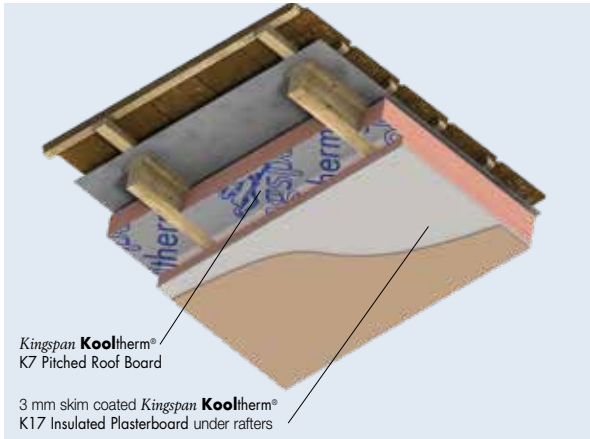

Figure 7 – Mechanically Fixed to Timber Rafters with **Kingspan Kooltherm® K7 Pitched Roof Board** Between Rafters

- Sheets must always be placed with the long edge running across the joists or rafters, and all edges must be supported.
- Where joints between sheets of insulated plasterboard are unsupported by the timber joists / rafters, timber noggins should be installed.
- Each sheet of insulated plasterboard should lap joists / rafters / noggins by 19 mm (min.) at sheet joints.
- Sheets should be fixed using either drywall screws at 230 mm centres, or large-headed galvanized clout nails placed at 150 mm centres.
- Each sheet of insulated plasterboard should be lightly butted, with fixings located no less than 10 mm from the bound edges of the sheet. Fixings should be long enough to allow a minimum 25 mm penetration of the timber.
- Fixings should be driven straight, with the heads embedded just below the surface of the plasterboard.
- Care should be taken not to overdrive nails / screws.
- The perimeter of the **Kingspan Kooltherm® K17 Insulated Plasterboard** should be sealed with a flexible sealant or equivalent.

Fixing Heavy Internal Fittings

- Suitable mechanical fixings should be used for heavy internal fittings (kitchen units, shelving etc), to ensure the load is applied direct to the supporting wall and not to the **Kingspan Kooltherm® K17 Insulated Plasterboard**.

For details on fixings refer to:

Tiger Fixings +44 (0) 8456 038 877
www.tigerfixings.com

MAK Fasteners +353 (0) 1 451 99 00
www.makfasteners.com

Fischer Fixings +353 (0) 1 642 6700
www.fischer.ie

- Alternatively, where there are to be extensive heavy internal fittings, the construction outlined in Figure 8 can be adopted.

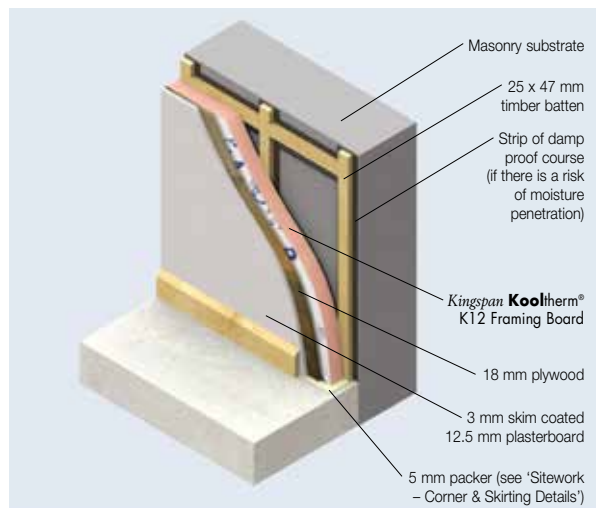

Figure 8

- Vertical timber framing studs / battens should be set at maximum 600 mm horizontal centres.
- If fixing to battens, they should be mechanically fixed to the wall, and comprise 25 x 47 mm (min.) treated softwood, backed with a strip of damp proof course (DPC).
- **Kingspan Kooltherm® K12 Framing Board** should be cut approximately 5 mm short of the floor to ceiling height.
- Where insulation board joints are unsupported by the timber framing studs / battens, timber noggins should be installed.

Sitework

- Each insulation board should lap timber framing studs / battens / noggins by 19 mm (min.) at board joints.
- Boards of **Kingspan Kooltherm® K12 Framing Board** should be temporarily fixed / nailed to timber framing studs / battens.
- 18 mm plywood should then be fixed through insulation boards to the timber framing studs / battens, using either drywall screws at 300 mm centres, or large headed galvanised clout nails at 150 mm centres.
- When fixing plywood through the insulation boards onto timber battens, fixings should be located no less than 10 mm from the bound edges of the sheets, and be long enough to allow minimum 22.5 mm penetration of the timber. Fixings should not penetrate through the battens.
- When fixing plywood through the insulation boards onto a timber frame, fixings should be located no less than 10 mm from the bound edges of the sheets, and be long enough to allow a minimum 25 mm penetration of the timber.
- Fixings should be driven straight, with the heads embedded just below the surface of the plywood.
- 12.5 mm plasterboard is then fixed to the plywood, using either drywall screws at 300 mm centres, or large headed galvanised clout nails at 150 mm centres.
- Fixings should be driven straight, with the heads embedded just below the surface of the plasterboard.
- Care should be taken not to overdrive nails / screws.
- The 5 mm clearance gap at the base of the wall should be sealed with a flexible sealant or equivalent.
- Heavy fittings can be fixed through the plasterboard directly to the plywood.

Corner & Skirting Details

- For external corners (including reveals), the lining should run past the corner and the insulating backing of **Kingspan Kooltherm® K17 Insulated Plasterboard** should be cut back to create a junction (see Figures 9 & 10). Sheets should be cut and rebated to allow a plasterboard / plasterboard joint at the angle (see Figures 9 & 10).
- Ensure sheets are lightly butted and air gaps minimised to reduce the risk of cold bridging (see Figures 9 & 11). Any air gaps should be sealed with flexible sealant or equivalent, or a combination of flexible polyurethane foam and flexible sealant or equivalent.

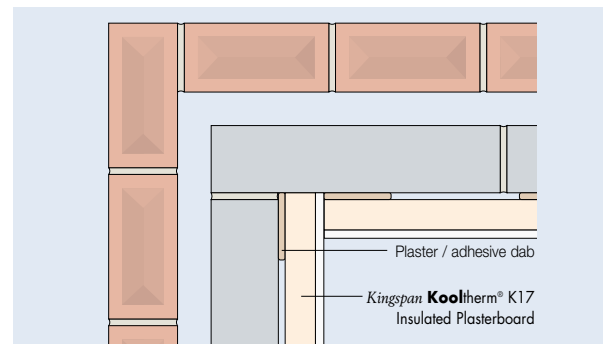

Figure 9 – Internal corner detail

- For adhesively bonded applications, a 15 mm packer should be used at the base of the wall to provide a level surface from which to build up the boards.
- The packer should be replaced with a combination of flexible polyurethane foam and flexible sealant or equivalent (see Figure 10).

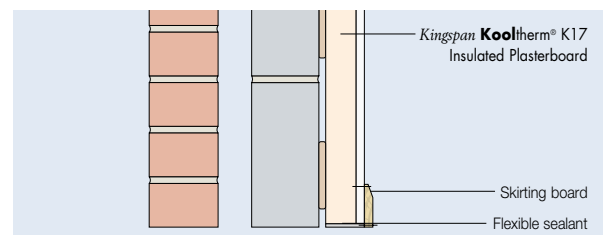

Figure 10 – Packer and Skirting Detail

Window / Door Reveals, Separating / Internal Walls & Soffit / Head Details

- Reveal lining can be either bonded in place or mechanically fixed. Secondary fixings should be used when bonding the lining in place.
- A 32.5 mm sheet of **Kingspan Kooltherm® K17 Insulated Plasterboard** should be used to line the window or door reveals. Where the depth of the window or door frames does not allow for this, the reveal can be cut back or the existing lining can be removed.
- The junction of the external wall and separating / internal wall should also be insulated with 32.5 mm (min.) of **Kingspan Kooltherm® K17 Insulated Plasterboard**, for a minimum distance of 400 mm back from the external wall lining.

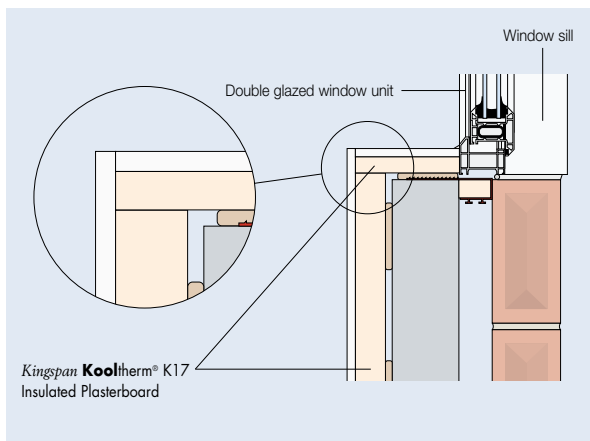

Figure 10 – Insulated reveal and external corner

Finishing

- To avoid air leakage, any penetrations through the insulation (electrical sockets, plumbing and wiring etc) should be sealed with flexible sealant or equivalent, or a combination of flexible polyurethane foam and flexible sealant or equivalent.
- Any remaining gaps between boards / sheets of insulation / interfaces etc. should be filled with flexible sealant or equivalent, or a combination of flexible polyurethane foam and flexible sealant or equivalent.
- Tapered edged boards allow the employment of standard dry-lining techniques.
- Plasterboard tape should be employed at all board joints, and a plaster skim finish applied.
- The skimming should be carried out in accordance with the specified plaster manufacturer's instructions, particularly in relation to the need to allow thorough drying of the plaster prior to decoration.

General

Cutting

- Cutting should be carried out either by using a fine toothed saw, or by using a sharp knife to cut through the insulation and paper backing of the plasterboard, then snapping the sheet face down over a straight edge and cutting the paper facing of the plasterboard on the other side.
- Ensure accurate trimming to achieve close butting joints and continuity of insulation.

Availability

- **Kingspan Kooltherm® K17 Insulated Plasterboard** is available through specialist insulation distributors and selected builders' merchants throughout the UK and Ireland.

Packaging and Storage

- The polyethylene packaging of Kingspan Insulation products, which is recyclable, should not be considered adequate for outdoor protection.
- Ideally sheets should be stored inside a building. If, however, temporary outdoor storage cannot be avoided then the sheets should be stacked flat on a level base, clear of the ground, and completely protected from inclement weather by use of an opaque polythene sheet or weatherproof tarpaulin. Sheets that have been allowed to get wet should not be used.

Health and Safety

- Kingspan Insulation products are chemically inert and safe to use.
- A Safety Information Data Sheet for this product is available from the Kingspan Insulation website www.kingspaninsulation.co.uk/safety or www.kingspaninsulation.ie/safety.

Please note that the reflective surfaces on this product are designed to enhance its thermal performance. As such, they will reflect light as well as heat, including ultraviolet light. Therefore, if this product is being installed during very bright or sunny weather, it is advisable to wear UV protective sunglasses or goggles, and if the skin is exposed for a significant period of time, to protect the bare skin with a UV block sun cream.

The reflective facings used on this product can be slippery when wet. Therefore, it is recommended that any excess material should be contained to avoid a slip hazard.

Warning – do not stand on or otherwise support your weight on this product unless it is fully supported by a load bearing surface.

Product Details

The Front Facing

The front facing of *Kingspan Kooltherm® K17 Insulated Plasterboard* is a tapered edge gypsum based plasterboard which readily accepts dry-jointing materials and plaster skim.

The Core

The core of *Kingspan Kooltherm® K17 Insulated Plasterboard* is a premium performance fibre-free rigid thermoset phenolic insulant manufactured with a blowing agent that has zero Ozone Depletion Potential (ODP) and low Global Warming Potential (GWP).



The Reverse Face

The reverse facing of *Kingspan Kooltherm® K17 Insulated Plasterboard* is a glass tissue based facing, autohesively bonded to the insulation core during manufacture.

Standards and Approvals

Kingspan Kooltherm® K17 Insulated Plasterboard is manufactured to the highest standards under a management system certified to ISO 9001: 2008 (Quality Management Systems. Requirements), ISO 14001: 2004 (Environmental Management Systems. Requirements), BS OHSAS 18001: 2007 (Occupational Health & Safety Management Systems. Requirements) and ISO 50001: 2011 (Energy Management Systems. Requirements with guidance for use).

The use of *Kingspan Kooltherm® K17 Insulated Plasterboard*, produced at Kingspan Insulation's Pembroke manufacturing facility is covered by BBA Certificate 14/5134, and that produced at Kingspan Insulation's Castleblayney manufacturing facility, is covered by NSAI Agrément Certificate 09/0329.



Standard Dimensions

Kingspan Kooltherm K17 Insulated Plasterboard is available in the following standard size:

Nominal Dimension		Availability
Length	(m)	2.4
Width	(m)	1.2
Plasterboard Thickness	(mm)	12.5
Insulant Thickness	(mm)	Refer to local distributor or Kingspan Insulation price list for current stock and non-stock sizes.

Compressive Strength

The compressive strength of *Kingspan Kooltherm® K17 Insulated Plasterboard* typically exceeds 100 kPa, when tested to BS / I.S. EN 826: 2013 (Thermal insulating products for building applications. Determination of compression behaviour).

Water Vapour Resistance

Adjusted for the effect of board joints, non-plasterboard component of the product typically achieves a resistance far greater than 100 MN-s/g, when tested in accordance with BS EN 12086: 1997 / I.S. EN 12086: 1998 (Thermal insulating products for building applications. Determination of water vapour transmission properties). For the purposes of calculation of condensation risk, the resistivity of the plasterboard component of the product should be taken as 50 MN-s/g.m.

Durability

If correctly installed, *Kingspan Kooltherm® K17 Insulated Plasterboard* can have an indefinite life. Its durability depends on the supporting structure and the conditions of its use.

Resistance to Solvents, Fungi & Rodents

The insulation core is resistant to short-term contact with petrol and with most dilute acids, alkalis and mineral oils. However, it is recommended that any spills be cleaned off fully before the boards are installed. Ensure that safe methods of cleaning are used, as recommended by the suppliers of the spilt liquid. The insulation core is not resistant to some solvent-based adhesive systems, particularly those containing methyl ethyl ketone. Adhesives containing such solvents should not be used in association with this product. Damaged boards or boards that have been in contact with harsh solvents or acids should not be used.

The insulation core and facings used in the manufacture of *Kingspan Kooltherm® K17 Insulated Plasterboard* resist attack by mould and microbial growth and do not provide any food value to vermin.

Kingspan Insulation

Fire Performance

Kingspan Kooltherm® K17 Insulated Plasterboard is Class 0, as defined by the Building Regulations. *Kingspan Kooltherm*® K17 Insulated Plasterboard, when subjected to EN ISO 5659-2: 2012 (Plastics. Smoke generation. Part 2: Determination of optical density by a single-chamber test), has achieved a mean maximum specific optical density of smoke < 200 in both the presence and absence of a pilot flame at irradiances of 25 and 50 kW/m².

Further details of the fire performance of Kingspan Insulation products may be obtained from the Kingspan Insulation Technical Service Department (see rear cover).

Thermal Properties

The λ -values and R-values detailed below are quoted in accordance with BS EN 13166: 2012 + A2: 2016 (Thermal insulation products for buildings – Factory made products of phenolic foam (PF) – Specification).

Thermal Conductivity

The thermal conductivity (λ -value) of the plasterboard component of *Kingspan Kooltherm*® K17 Insulated Plasterboard is 0.19 W/m·K.

The thermal conductivity (λ -value) of the insulation core of *Kingspan Kooltherm*® K17 Insulated Plasterboard is: 0.023 W/m·K (insulant thickness 15–24); 0.021 W/m·K (insulant thickness 25–44 mm); and 0.020 W/m·K (insulant thickness \geq 45 mm).

Thermal Resistance

Thermal resistance (R-value) varies with the thickness of each component. It is calculated by dividing the thickness of each component (expressed in metres) by its thermal conductivity, followed by adding the resulting figures together. The sum is rounded down to the nearest 0.05 (m²·K/W).

*Product Thickness (mm)	Thermal Resistance (m ² ·K/W)
32.5	0.90
37.5	1.25
42.5	1.45
47.5	1.70
52.5	1.95
57.5	2.30
62.5	2.55
67.5	2.80
72.5	3.05
82.5	3.55
87.5	3.80
92.5	4.05

* Product thickness = insulation thickness + 12.5 mm plasterboard.

NB Refer to local distributor or Kingspan Insulation price list for current stock and non-stock sizes.

Insulation Product Benefits

Kingspan OPTIM-R® Vacuum Insulation Panel (VIP) Products

- With a declared value thermal conductivity of 0.007 W/m·K, these products provide an insulating performance that is up to five times better than commonly used insulation materials.
- Provides high levels of thermal efficiency with minimal thickness.
- Over 90% (by weight) recyclable.

Kingspan Kooltherm® Range Products

- With a thermal conductivity of 0.018–0.023 W/m·K these are the most thermally efficient insulation products commonly used.
- The thinnest commonly used insulation products for any specific U-value.
- Manufactured with a blowing agent that has zero Ozone Depletion Potential (ODP) and low Global Warming Potential (GWP).

Kingspan Therma™ Range Products

- With a thermal conductivity of 0.022–0.028 W/m·K these are amongst the more thermally efficient insulation products commonly used.
- Manufactured with a blowing agent that has zero Ozone Depletion Potential (ODP) and low Global Warming Potential (GWP).

Kingspan Styrozone® Range Products

- Rigid extruded polystyrene insulation (XPS) has the necessary compressive strength to make it the product of choice for specialist applications such as heavy duty flooring, car park decks and inverted roofing.
- Manufactured with a blowing agent that has zero Ozone Depletion Potential (ODP).

All Products

- Unaffected by air infiltration – a problem that can be experienced with mineral fibre and which can reduce thermal performance.
- Safe and easy to install.
- If installed correctly, can provide reliable long term thermal performance over the lifetime of the building.
- Each product achieves the required fire performance for its intended application.

Contact Details

Customer Service

For quotations, order placement and details of despatches please contact the Kingspan Insulation Customer Service Department on the numbers below:

UK – Tel: +44 (0) 1544 388 601
– Fax: +44 (0) 1544 388 888
– email: customerservice@kingspaninsulation.co.uk

Ireland – Tel: +353 (0) 42 979 5000
– Fax: +353 (0) 42 975 4299
– email: info@kingspaninsulation.ie

Literature & Samples

Kingspan Insulation produces a comprehensive range of technical literature for specifiers, contractors, stockists and end users. The literature contains clear user friendly advice on typical design; design considerations; thermal properties; sitework and product data.

For copies please contact the Kingspan Insulation Marketing Department, or visit the Kingspan Insulation website, using the details below:

UK – Tel: +44 (0) 1544 387 384
– Fax: +44 (0) 1544 387 484
– email: literature@kingspaninsulation.co.uk
– www.kingspaninsulation.co.uk/literature

Ireland – Tel: +353 (0) 42 979 5000
– Fax: +353 (0) 42 975 4299
– email: info@kingspaninsulation.ie
– www.kingspaninsulation.ie/literature

Tapered Roofing

For technical guidance, quotations, order placement and details of despatches please contact the Kingspan Insulation Tapered Roofing Department on the numbers below:

UK – Tel: +44 (0) 1544 387 383
– Fax: +44 (0) 1544 387 483
– email: tapered@kingspaninsulation.co.uk

Ireland – Tel: +353 (0) 42 975 4297
– Fax: +353 (0) 42 975 4296
– email: tapered@kingspaninsulation.ie

Technical Advice / Design

Kingspan Insulation supports all of its products with a comprehensive Technical Advisory Service. Calculations can be carried out to provide U-values, condensation / dew point risk, required insulation thicknesses etc...

U-value calculations can also be carried out on the Kingspan Insulation U-value Calculator, available for free online at www.uvalue-calculator.co.uk or downloaded as an App.



The Kingspan Insulation Technical Service Department can also give general application advice and advice on design detailing and fixing etc... Site surveys are also undertaken as appropriate.

The Kingspan Insulation British Technical Service Department operates under a management system certified to the BBA Scheme for Assessing the Competency of Persons to Undertake U-value and Condensation Risk Calculations.



Please contact the Kingspan Insulation Technical Service Department on the numbers below:

UK – Tel: +44 (0) 1544 387 382
– Fax: +44 (0) 1544 387 482
– email: technical@kingspaninsulation.co.uk

Ireland – Tel: +353 (0) 42 975 4297
– Fax: +353 (0) 42 975 4296
– email: technical@kingspaninsulation.ie

General Enquiries

For all other enquiries contact Kingspan Insulation on the numbers below:

UK – Tel: +44 (0) 1544 388 601
– Fax: +44 (0) 1544 388 888
– email: info@kingspaninsulation.co.uk

Ireland – Tel: +353 (0) 42 979 5000
– Fax: +353 (0) 42 975 4299
– email: info@kingspaninsulation.ie

Kingspan Insulation Ltd. reserves the right to amend product specifications without prior notice. Product thicknesses shown in this document should not be taken as being available ex-stock and reference should be made to the current Kingspan Insulation price-list or advice sought from Kingspan Insulation's Customer Service Department (see above left). The information, technical details and fixing instructions etc. included in this literature are given in good faith and apply to uses described. Recommendations for use should be verified for suitability and compliance with actual requirements, specifications and any applicable laws and regulations. For other applications or conditions of use, Kingspan Insulation offers a Technical Advisory Service (see above), the advice of which should be sought for uses of Kingspan Insulation products that are not specifically described herein. Please check that your copy of this literature is current by contacting the Kingspan Insulation Marketing Department (see left).



Kingspan Insulation Ltd

Pembridge, Leominster, Herefordshire HR6 9LA, UK
Castleblayney, County Monaghan, Ireland

www.kingspaninsulation.co.uk www.kingspaninsulation.ie